

User Manual

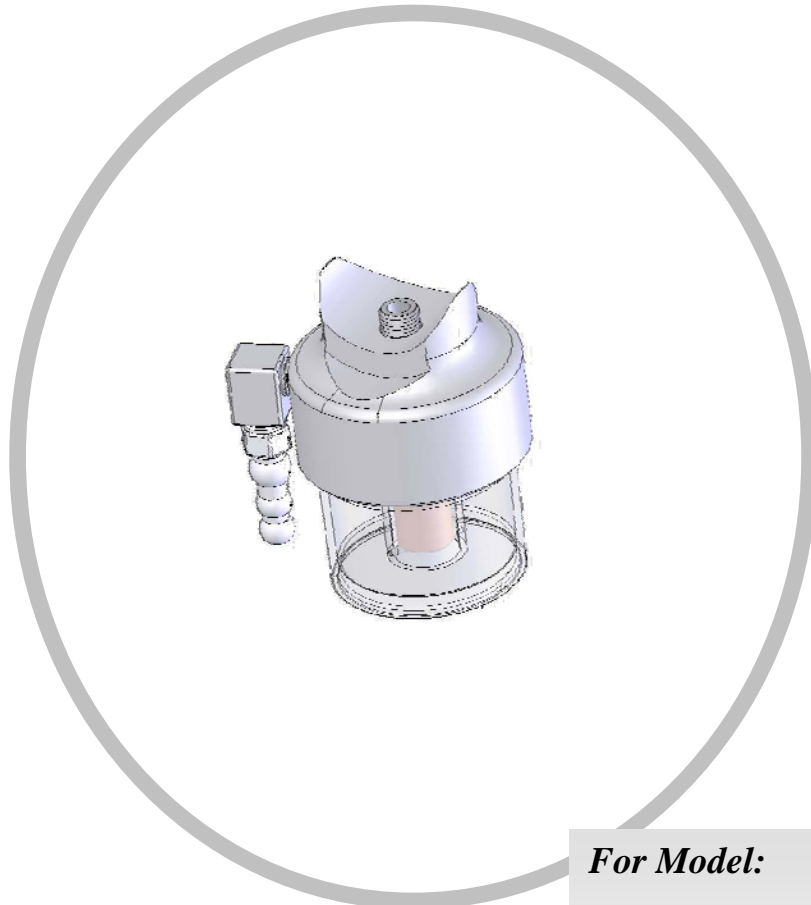

For Model:

9100 – Integral Trap

BOEHRINGER®

**Boehringer Laboratories, LLC
300 Thoms Dr.
Phoenixville, PA 19460
800-642-4945**

WELCOME

Congratulations on your purchase of a Boehringer Trap Bottle. We consider our products to be the best in the world. We are confident they will provide you with reliable, trouble-free, safe patient care and low cost of operation. This product is intended for use by individuals properly trained in suctioning procedures by or on the order of a physician. Please read these instructions carefully.

Contents

Definition of Terms/ Symbology	3
Safety Information	3
Clinical Use.....	3
Operation.....	4
Installation	4
Maintenance.....	5
Test.....	5
Cleaning & Disinfection	6
Disassembly	6
Assembly.....	7
Troubleshooting.....	7
Specifications	7
Warranty	8
Diagrams.....	9

Definition of Terms and Symbology

VACUUM	Air or other gases at a sub atmospheric pressure typically expressed as mmHg or cmH ₂ O.
SUCTION	A use of vacuum that causes a fluid or solid to be drawn into an interior space or to adhere to a surface because of the difference between the external and internal pressures.
	Alerts the user to the presence important operating and maintenance instructions in the literature accompanying the device.
WARNING	Alerts user to actions or conditions that could result in injury to user or patient.
CAUTION	Alerts user to actions or conditions that can cause damage to the device <u>or</u> may result in substandard performance of the device or system.
IMPORTANT	Indicates an action that is emphasized to ensure proper operation of equipment.

Safety Information

WARNING!

- The use of a trap bottle does not preclude the need for an inline canister system. The volume of the trap bottle is only meant to provide overflow protection, it is not meant to be the primary collection canister in the system.
- Given the position of the suction trap in a standard collection system it is possible for the gauge on the regulator to show the presence of suction but for suction to not be available at the patient connection. This can happen when the Safety trap has shut off downstream suction due to fluid intrusion. The clinician should verify adequate suction is available at the patient connection prior to initiating any suction therapy. If the RED float in the trap bottle is not visible, this is a sign that material has caused the trap bottle to shut off the suction system.
- Verify the trap bottle is clear and free of any foreign matter prior to the initiation of any suction therapy. If any foreign material is visible in the clear suction trap bottle, have the unit serviced before delivery patient care with the unit. Simply replacing or cleaning the trap bottle may not be adequate service to ensure continued operation.
- The RED float inside of the trap bottle must be installed for the proper operation of the trap bottle. Failure to replace the RED float will disable the fluid shutoff protection provided by the trap bottle.

CLINICAL USE

The 9100 Series Trap Bottles are meant to provide overflow protection to ensure collected materials do not enter the internal components of the suction regulator, or the central suction system.

Operation

FEATURES

MODEL 9100 TRAP BOTTLE

Form Fitting Attachment: Only found on the Model 9100, further reduces the amount of space required to mount the Trap Bottle.

Vertical Suction Exit: Allows for a more traditional tubing layout and avoids the possibility of kinking suction tubing when using a trap bottle.

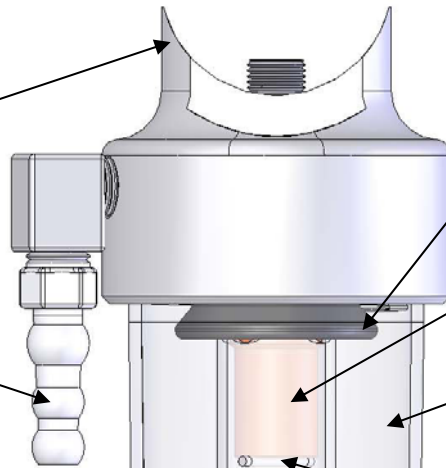

Shield: Deflects incoming liquids and vapors to prevent entry into the suction system.

Float: Bright colored indicator to show the trap is still open.

60cc Bottle: Compact size reduces the space needed.

Float Retainer: Prevents the float from being inadvertently disposed of during maintenance.

INSTALLATION

The 9100 Integral Trap bottle is factory installed when chosen as an option for the 3800 and 7800 series suction regulators. This can also be field installed by disassembling the unit to allow for access to the threaded screw on the inside of the. Directions for how to disassemble the 9100 trap bottle are found below.

7700 & 7800 Series Installation

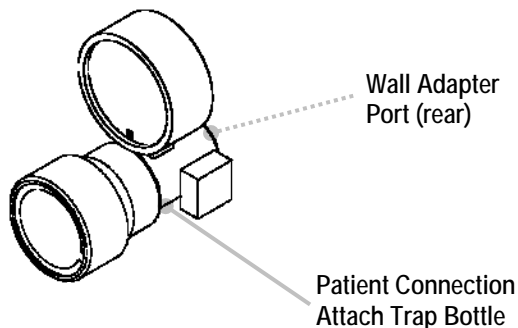

3700 & 3800 Series Installation

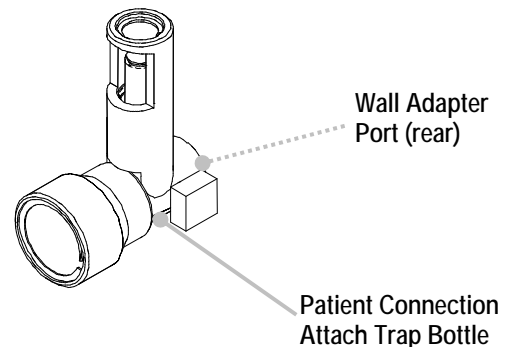

MAINTENANCE

Your Boehringer Suction Trap Bottle has been designed to provide years of trouble free operation. Most service activity is the result of aspiration of bodily fluids or other foreign materials into the working mechanism of the regulator. The routine use of an appropriate collection canister greatly reduces needed service. To determine your cleaning/maintenance schedule:

- Periodically inspect the overall condition of the bottle of the unit. Any discoloration or material inside of the bottle is an indication material has been pulled into the device.
- If fluid has been drawn into the device, causing the shut-off to activate, ensure the unit is properly cleaned before returning it to service.
- Based on data from your periodic inspections, determine a cleaning/maintenance schedule appropriate for the operational conditions of your facility. Clean, inspect, lubricate, and test based on your schedule and according to the Instrument Cleaning and Disinfection, Instrument Lubrication and 'Test' section outlined below.

TEST

1. Ensure the Trap bottle is properly attached to the suction regulator.
2. Verify that the trap bottle components have been properly installed.
3. Verify the trap bottle is firmly tightened down to avoid any leaks.
4. Connect a collection canister to the upstream end of the suction regulator. This will capture any fluid that may bypass an inoperative trap bottle during this test.

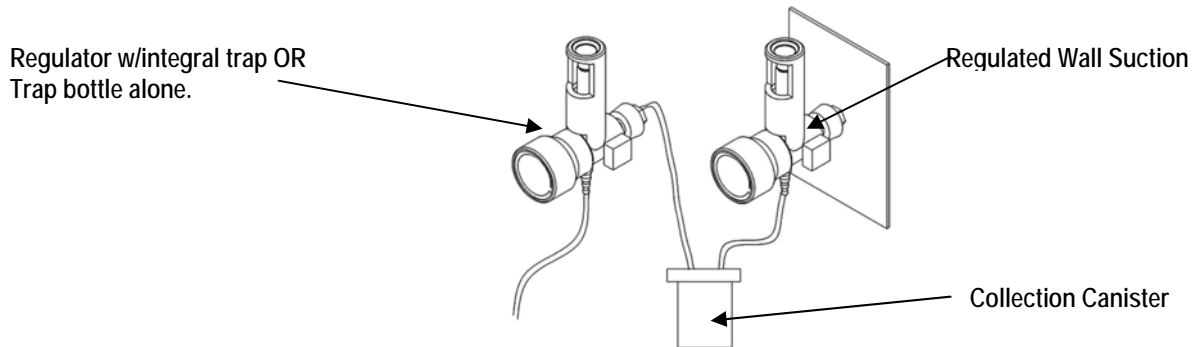

5. Connect a standard length of suction tubing to the outlet of the trap bottle. This would typically be 2 meters of 6mm ID tubing. At the end of the suction tubing connect a 14Fr. Catheter.
6. Turn the regulator on to its highest setting. Open and close the downstream suction tubing by alternatively kinking and unkinking the tubing of the catheter. The trap bottle must not shut off suction. The trap would indicate it is shut off by turning off the suction to the downstream tubing, or raising the RED float out of the field of view.
7. Challenge the collection circuit with 50cc of water. This can be done by dunking the 14Fr catheter into a beaker containing the water.
8. The float inside of the trap must shut the circuit off and not allow more than 3cc of water to bypass the mechanism. Once the float shuts the system off, you must not see fluid continue to travel in the suction catheter.

Cleaning & Disinfection

Please refer to Boehringer document 7700.192, Boehringer Suction Regulator Recommendations for Decontamination and Autoclaving for guidance. This information is available online at www.boehringerlabs.com, or toll-free at 1-800-642-4945.

DISASSEMBLY

Model 9100 Integral Trap Bottle (See Fig. 1)

1. Unscrew the clear bottle (33701) from the unit. Clean this as necessary.
2. Remove flexible shield (33700) by pulling it over the top of the clear float retainer.
3. Wiggle and remove float shield (33698) from the housing. This is retained with a friction fit and it does not need to be unscrewed to remove it.

Note: Under normal circumstances it is not necessary to remove the retainer screw (33783) from the unit. For most service needed for both the regulator and the trap bottle this can be maintained in place.

The float retention pin (33704) is factor installed and should not be removed.

ASSEMBLY

Assembly Models 9100

After disassembling and cleaning the instrument, assemble as follows. Parts are available from Boehringer Laboratories, LLC and may be ordered by part number (P/N).

1. Ensure the bottle seal o-ring (33702) is not ripped or torn. A tear in this seal will reduce the flow of suction available for clinical procedures. Install this o-ring into the base of the threaded area of the tap manifold (33697 or 33778).
2. Ensure float seal (33705) is clean and free of cuts and tears. An degradation in this sealing surface would increase the possibility foreign matter could enter your suction regulators and central suction system. Place this seal into the base of the float manifold as shown in the cutaway drawings.
3. Place Float (33699) into float retainer (33698) so that the open end of the float faces towards the float retention pin (33704).
4. Place float shield o-ring (33789) over the float shield (33698) so that it rests in the grooved area nearest the large holes in this part. The float shield o-ring (33789) does not function as a seal, but it must be snug enough upon assembly to retain the float in place.
5. Install the float retainer (33698) into the manifold. You may need to wiggle this since there is a pressure fit. The float retainer o-ring (33789) will snap in place when this has been properly positioned.
6. Screw the trap bottle (33701) onto trap manifold (33697 or 33778). Ensure this bottle seals adequately to prevent any loss in suction.
7. Test the reassembled trap bottle as described in the TEST section.

 See the Test section, page 7, for exact test procedure.

TROUBLESHOOTING

Complete Technical Manuals and Service Bulletins can be found at
<http://www.boehringerlabs.com/support/suction-regulator-technical-manuals.php>

Video Tips and Techniques for use and repair can be found at:
<http://www.boehringerlabs.com/support/video/product-videos.php>
<http://www.youtube.com/boehringerlabsllc>

Boehringer Suction Regulators have been designed for years of trouble-free service. Should you experience difficulty that is not the result of damage to the instrument, the most likely cause is aspiration of dirt and/or fluids into the Regulator.

Symptom	Probable Cause	Solution
Suction not available at patient port.	Trap bottle has accumulated debris.	Clean, replace, and test as needed to remove foreign matter.
Suction not available at patient port, but no material is visible inside of trap bottle.	High flow suction has inadvertently tripped the float mechanism of the trap bottle.	Turn off the suction regulator and allow the red suction float to drop into view in the trap bottle. Attach an appropriate patient collection circuit before turning the regulator back on.
Insufficient suction/flow available at the patient port.	Trap bottle 33701 improperly sealed.	Ensure the trap bottle is properly threaded. Ensure attachment to the regulator (33783 or 33291) is properly threaded and an appropriate thread sealant has been used.
Fluid bypasses the trap bottle.	Float or seal not in place.	Ensure the red float (33699) is installed and the float seal (33705) is in place and free of debris.

IMPORTANT! Always test the reassembled unit after each maintenance procedure.

SPECIFICATIONS

- Inlet fittings: 1/8 NPT
- Outlet fitting: Proprietary Boehringer Model 2469 high flow bubble barb
- Materials: polycarbonate, hard-anodized aluminum, stainless steel, Buna-N rubber, acetal copolymer, silicone rubber.

Warranty and Repair

Boehringer Laboratories, LLC guarantees all Model 9100 integral trap bottles for TWELVE years or the length of the warranty of the regulator on which it was factory installed, whichever is lesser.

Boehringer Laboratories, LLC warrants to the original purchaser, new suction regulators purchased directly from Boehringer Laboratories, LLC or from an authorized dealer or representative. This warranty guarantees the suction regulators to be free from functional defects in materials and workmanship. We also guarantee that our suction regulators will meet our published specifications.

All regulators returned for repair shall be clean and free from contamination prior to shipment to Boehringer Laboratories. This requirement is for the safety of our employees as well as to comply with Federal Law prohibiting the shipment of unmarked biohazard materials. If units are returned contaminated, a cleaning charge may result.

A service charge may be assessed on any unit returned that shows evidence of gross abuse.

Boehringer Laboratories, LLC is the only authorized warranty service center for our suction regulators. Any repair service requesting a return authorization for repair will be asked to provide the name and location of the original equipment purchaser. If this information cannot be provided, the repair is not covered under warranty and will be a chargeable repair.

This warranty excludes acts of God, fire, flood and acts of war, terror or insurrection.

This warranty is not transferable from the original purchaser.

Boehringer Laboratories' sole and exclusive remedy under this warranty is limited to repairing and/or replacing the suction regulator. There are no other express or implied warranties beyond these warranties set forth above. At Boehringer Laboratories, we are committed to lowering your suction regulator costs of operation!



All repairs will be shipped back within five days of receipt of purchase order authorization.

For quality factory service, call 800-642-4945 or 610-278-0900 for your return authorization. Ship returns to:

**Boehringer Laboratories, LLC
Repair Department
300 Thoms. Dr.
Phoenixville, PA 19460**

New Products

We are continually striving to reach higher and higher standards of quality. We value your comments and input on our suction regulators. If you are pleased with this instrument, please find out more about Boehringer Laboratories' complete line of suction controls.

FIGURE 1
Models 9100 Integral Trap Bottle

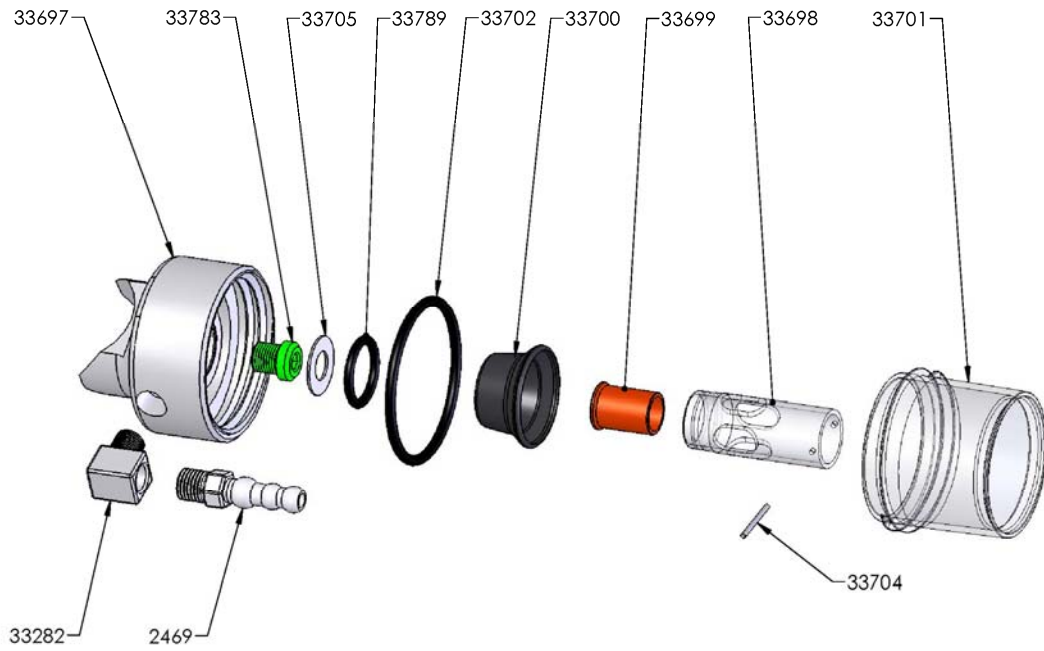

BOEHRINGER®

Boehringer Laboratories, LLC
300 Thoms Dr.
Phoenixville, PA 19460

For
Customer Service
Or
Technical Support

800-642-4945

www.boehringerlabs.com

***A free trial evaluation
of any of our suction regulators
can be arranged by calling
(800) 642-4945 or 610-278-0900.***